

SAFETY MANUAL

HART TRANSPARENT REPEATER

9106

**This safety manual is valid for the following product versions:
9106-002**

0. CONTENTS

1. Observed standards	2
2. Acronyms and abbreviations	2
3. Purpose of the product	3
4. Assumptions and restrictions for use of the product.....	3
4.1 Basic safety specifications	3
4.2 Safety accuracy	3
4.3 Analogue output	3
4.4. Failure rates	3
4.5 Installation in hazardous areas	4
4.6. Installation in SIL 3 applications.....	4
5. Functional specification of the safety functions.....	4
6. Functional specification of the non-safety functions	4
7. Safety parameters	5
8. Hardware and software configuration.	6
9. Failure category SIL 2 / SIL 3.....	7
10. Periodic proof test procedure	7
11. Procedures to repair or replace the product.....	7
12. Maintenance	7
13. Connections diagram	8

1. Observed standards

Standard	Description
IEC 61508	Functional Safety of electrical / electronic / programmable electronic safety-related systems
IEC 61508-2:2000	Part 2: Requirements for electrical / electronic / programmable electronic safety-related systems

2. Acronyms and abbreviations

Acronym / Abbreviation	Designation	Description
Element		Term defined by IEC 61508 as “part of a subsystem comprising a single component or any group of components that performs one or more element safety functions”
PFD	Probability of Failure on Demand	This is the likelihood of dangerous safety function failures occurring on demand.
PFH	Probability of dangerous Failure per Hour	The term “Probability” is misleading, as IEC 61508 defines a Rate.
SFF	Safe Failure Fraction	Safe Failure Fraction summarises the fraction of failures which lead to a safe state and the fraction of failures which will be detected by diagnostic measures and lead to a defined safety action.
SIF	Safety Integrity Function	Function that provides fault detection (to ensure the necessary safety integrity for the safety functions)
SIL	Safety Integrity Level	The international standard IEC 61508 specifies four discrete safety integrity levels (SIL 1 to SIL 4). Each level corresponds to a specific probability range regarding the failure of a safety function.

3. Purpose of the product

HART transparent, galvanic isolation and repetition of passive and active 4...20 mA current signals from hazardous area to non-classified area.

The module can be mounted in non-classified area or in zone 2 / Div. 2 and receive current signals from zone 0, 1, 2, 20, 21, 22 and mines or Class I/II/III, Div. 1, Group. A-G.

Error events, including cable breakage, are monitored and signalled via the individual status relay and/or a collective electronic signal via the power rail.

The display and programming module 4501 can be used to show the actual process values, and alter the set point for high and low limit.

The 9106 has been designed, developed and certified for use in SIL applications according to the requirements of IEC 61508

4. Assumptions and restrictions for use of the product

4.1 Basic safety specifications

Operational temperature range	-20...+60°C
Storage temperature range	-20...+85°C
Power supply type.....	Double or reinforced
Supply voltage.....	19.2...31.2 VDC
Loop supply 9106B1	16V @ 20mA
Loop supply 9106B2	15V @ 20mA
Max external output supply voltage.....	26 VDC
Mounting area.....	Class I, Zone 2/Division 2 or safe area
Mounting environment.....	Pollution degree 2, Overvoltage category II

4.2 Safety accuracy

The analogue output corresponds to the applied input within the safety accuracy.

Safety accuracy..... ±2%

4.3 Analogue output

The connected safety PLC shall be able to detect and handle the fault indications from the analogue output of the 9106 Repeater by having a NAMUR NE43-compliant input circuit.

4.4. Failure rates

The basic failure rates from the Siemens standard SN 29500 are used as the failure rate database.

Failure rates are constant, wear-out mechanisms are not included.

External power supply failure rates are not included.

4.5 Installation in hazardous areas

The IECEx Installation drawing, ATEX Installation drawing and FM Installation drawing shall be followed if the products are installed in or connected to hazardous areas.

4.6. Installation in SIL 3 applications

The independence of the safety functions enables the use of the two channels in a 9106 HART[®] Transparent Repeater device, in a SIL 3 safety function when both inputs are connected in series.

The safety PLC or equivalent connected to the output shall be able to detect and handle the fault indications from both analogue outputs of the 9106 Repeater by having NAMUR NE43-compliant input circuits and must be able to compare the two channels.

5. Functional specification of the safety functions

Galvanic isolation of an active or passive 4...20 mA current signal from hazardous areas to an active or passive 4..20 mA output signal in non-classified area or zone2 / Div. 2, within the specified accuracy.

6. Functional specification of the non-safety functions

The status relay (terminal 33 and 34), error signal on power rail (terminal 91) and LED outputs are not suitable for use in any Safety Instrumented Function. The display value and any possible parameterisation by the 4501 add on module does not affect the safety function of the 9106.

Also the HART[®] transparency of the module is not a safety function.

7. Safety parameters

Connection diagram	Ex input SIL 2
Probability of dangerous Failure per Hour (PFH)	4.10E-08
	Note ¹
Probability of failure on demand (PFD) - 1 year proof test interval	1.95E-04
Proof test interval (10% of loop PFD)	5 years
Safe Failure Fraction	88%
Demand mode	High
Demand rate	Note ³
Mean Time To Repair (MTTR)	24 hours
Hardware Fault Tolerance (HFT)	0
Component Type	A
SIL capability	SIL 2
Description of the "Safe State"	Output \leq 3.6 mA or Output \geq 21 mA

Connection diagram	Ex input SIL 3
Probability of dangerous Failure per Hour (PFH)	1.10E-08
	Note ¹
Probability of failure on demand (PFD) - 1 year proof test interval	4.27E-05
Proof test interval (10% of loop PFD)	2 years
Safe Failure Fraction	98%
Demand mode	High
Demand rate	Note ³
Mean Time To Repair (MTTR)	24 hours
Hardware Fault Tolerance (HFT)	0
Component Type	A, see Note ⁴
SIL capability	SIL 3, see Note ²
Description of the “Safe State”	Output \leq 3.6 mA or Output \geq 21 mA

Note¹: The 9106 contains no lifetime limiting components, therefore the PFH figures are valid for up to 12 years, according to IEC 61508.

Note²: The use of 9106 in SIL 3 applications requires that the connected PLC is suitable for SIL 3 applications. see paragraph 4.6.

Note³: Depends on detection time in external controller. If detection time is xx seconds, the Demand Rate shall be 100 times xx seconds.

Note⁴: Simple device (type A) where microprocessors and software have no effect on safety output.

8. Hardware and software configuration.

All configurations of software and hardware versions are fixed from factory, and cannot be changed by end-user or reseller.

This manual only covers products labelled with the product version (or range of versions) specified on the front page.

9. Failure category SIL 2 / SIL 3

Failure category	Failure rates (1/h) SIL 2
Fail Safe Detected	0.000E-0
Fail Safe Undetected	1.65E-07
Fail Dangerous Detected	1.60E-07
Fail Dangerous Undetected	4.10E-08

Failure category	Failure rates (1/h) SIL 3
Fail Safe Detected	0.000E-0
Fail Safe Undetected	3.05E-07
Fail Dangerous Detected	3.63E-07
Fail Dangerous Undetected	1.10E-08

10. Periodic proof test procedure

Step	Action
1	Bypass the safety PLC or take other appropriate action to avoid a false trip
2	Connect a simulator identical to the input setup
3	Apply input value corresponding to 0/100% output range to each channel
4	Observe whether the output channel acts as expected
5	Restore the input terminals to full operation
6	Remove the bypass from the safety PLC or otherwise restore normal operation

This test will detect approximately 95% of possible “du” (dangerous undetected) failures in the module.

11. Procedures to repair or replace the product

Any failures that are detected and that compromise functional safety should be reported to the sales department at PR electronics A/S.

Repair of the module and replacement of circuit breakers must be done by PR electronics A/S only.

12. Maintenance

No maintenance required.

13. Connections diagram

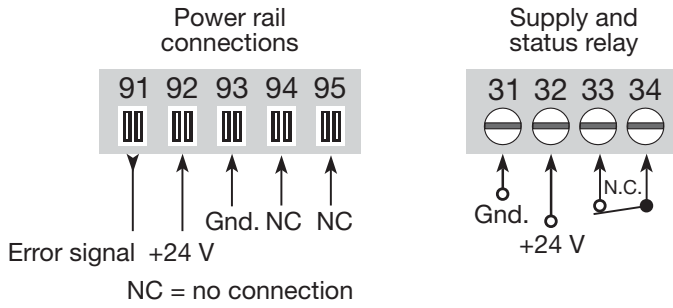

Ex inputs - SIL 2:

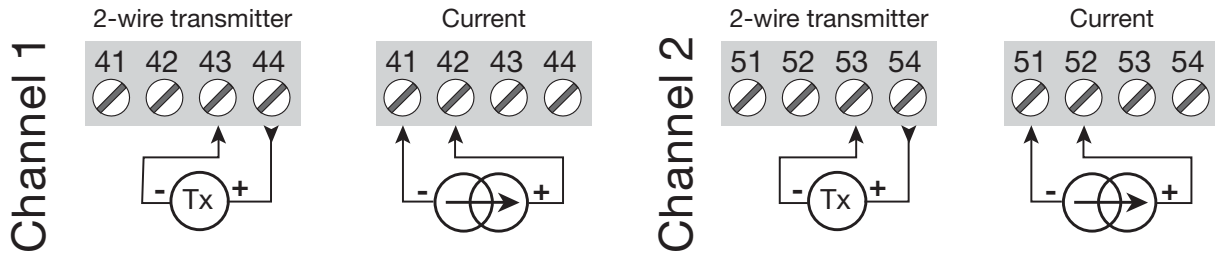

Ex inputs - SIL 3:

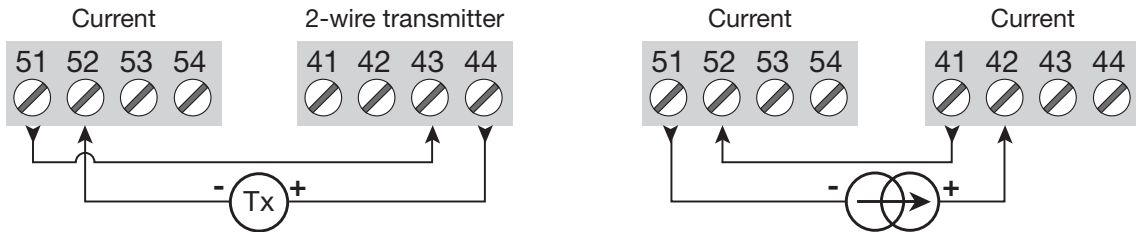

Outputs:

